

OUTDOOR

OPENINGS REMOTE

CONTROL



Ref : OPE-LAB-13NS



+ 20 years*

15km* IP68 (Outdoor use)

Local or Public Network compliant

*Depending on the operating conditions

THIS SENLAB™ D IS A SMART WIRELESS DEVICE, FEATURING THE LoRaWAN™ CONNECTIVITY PROTOCOL, EQUIPPED WITH A MAGNETIC DOOR SWITCH SET.

Designed for outdoor use, this Senlab™ offers a ruggedized IP68 casing for outdoor use which enables a reliable wireless connectivity for continuous monitoring in challenging environments.

This Senlab offers best in class features such as :

- **Battery Life time more than 20 years**
- **Rich data content**
- **Radio performances**
- **Advanced set of functionalities**

TYPICAL APPLICATIONS

- Implement activity-based services
- Control openings state

TYPICAL SPECIFICATIONS

Physical specifications	Dimensions	56 X 102 X 35 mm
	Weight	200 gr
	Operating temperature	-20°C to +70°C
RF specifications	RF sensitivity	-137dBm
	RF power	+14dBm (25mW)
	Radio band	868 MHz
EC Conformity : Compliant with Directive 2014/53/UE (RED)	EMC	Final draft EN 301 489-3 v2.1.1 Draft EN 301 489-1 v2.2.0
	Radio	EN 300 220-2 v3.1.1
	Magnetic field exposure	EN 62479
	Safety	EN 60950-1, EN 60950-22

DIMENSIONAL DRAWING

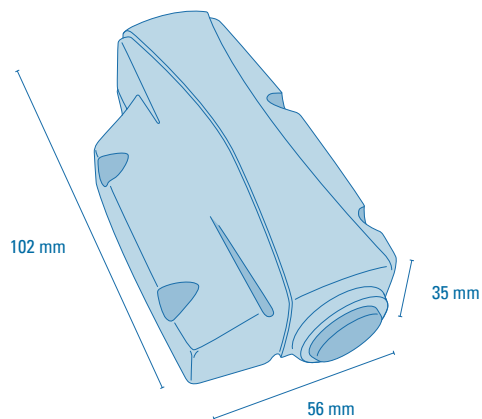

TECHNICAL FEATURES FOCUS

Plug & Play installation

- Product fixing with 2 cable ties on wall or pipe
- Door contact detection up to 3 cm
- Activation with magnet (LED feedback)

High configurability of event detection and transmission

- Event notification of open and/or close state
- State detection duration configurable
- Immediate transmission or after N events or after maximum duration
- Reconfiguration possible over the air

Network configuration

- LoRaWAN parameters (OTAA or ABP activation mode, initial datarate,...)
- Encryption keys customizable by client
- Standard LoRaWAN retries support
- Radio collisions avoidance by pseudo-randomization of transmissions
- Advanced transmission reliability mechanisms (recovery of lost messages, ...)

BATTERY LIFE DURATION ESTIMATION

This following matrix provides the estimated battery lifetime depending on the average spreading factor used by the Senlab and the transmission period.

Battery life (years)	10 min	15 min	30 min	1 h	2 h	4 h	6 h	8 h	12 h	24 h
SF7	16,4	18,2	>20	>20	>20	>20	>20	>20	>20	>20
SF8	13,6	15,8	18,8	>20	>20	>20	>20	>20	>20	>20
SF9	10,1	12,4	16,2	19,0	>20	>20	>20	>20	>20	>20
SF10	6,8	8,8	12,8	16,5	19,3	>20	>20	>20	>20	>20
SF11	4,2	5,8	9,3	13,2	16,8	19,5	>20	>20	>20	>20
SF12	2,5	3,5	6,1	9,7	13,6	17,2	18,8	19,7	>20	>20

A single event per frame.

For guidance and information purposes only.