

OUTDOOR EVENT AND ALARM MONITORING



SMART BUILDING



SMART INDUSTRY



Ref : TOR-LAB-13NS



+ 20 years*

15km* IP68 (Outdoor use)

Local or Public Network compliant

*Depending on the operating conditions

SENLAB™ D OUTDOOR IS A SMART WIRELESS DEVICE, FEATURING THE LoRaWAN™ CONNECTIVITY PROTOCOL, EQUIPPED WITH AN INTEGRATED DIGITAL INPUT SENSOR FOR ON/OFF OR OPEN/CLOSE STATE DETECTION.

Designed to monitor the status of relays, transistors, and switches and detect abnormalities, Senlab D IP68 offers a highly-configurable information reporting algorithm, notably for triggering alarms, counting, and more. It is ideal for your security or preventive maintenance needs.

This Senlab offers best in class features such as :

- **Battery Life time more than 20 years**
- **Radio performances**
- **Rich data content**
- **Advanced set of functionalities**

TYPICAL APPLICATIONS

- Alert and Event management for action triggering
- Monitor boiler, power generator, air conditioning state
- Remote control treatment plant pump

TYPICAL SPECIFICATIONS

Physical specifications	Dimensions	56 X 102 X 35 mm
	Weight	140 gr
	Operating temperature	-20°C to +70°C
RF specifications	RF sensitivity	-137dBm
	RF power	+14dBm (25mW)
	Radio band	868 MHz
EC Conformity : Compliant with Directive 2014/53/UE (RED)	EMC	Final draft EN 301 489-3 v2.1.1 Draft EN 301 489-1 v2.2.0
	Radio	EN 300 220-2 v3.1.1
	Magnetic field exposure	EN 62479
	Safety	EN 60950-1, EN 60950-22

DIMENSIONAL DRAWING

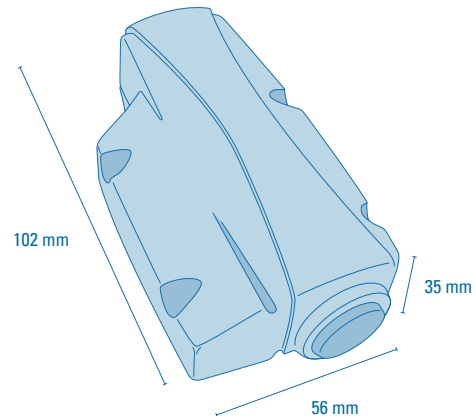

TECHNICAL FEATURES FOCUS

Plug & Play installation

- Product fixing with 2 cable ties on wall or pipe
- Provided with 1 meter cable ready to be plugged on digital sensor
- Activation with magnet (LED feedback)

High configurability of event detection and transmission

- Event notification of open/close or on/off digital state
- State detection duration configurable
- Immediate transmission or after N events or after maximum duration
- Reconfiguration possible over the air

Network configuration

- LoRaWAN parameters (OTAA or ABP activation mode, initial datarate,...)
- Encryption keys customizable by client
- Standard LoRaWAN retries support
- Radio collisions avoidance by pseudo-randomization of transmissions
- Advanced transmission reliability mechanisms (redundancy of data, recovery of lost messages, ...)

BATTERY LIFE DURATION ESTIMATION

This following matrix provides the estimated battery lifetime depending on the average spreading factor used by the Senlab and the transmission period.

Battery life (years)	10 min	15 min	30 min	1 h	2 h	4 h	6 h	8 h	12 h	24 h
SF7	16,4	18,2	>20	>20	>20	>20	>20	>20	>20	>20
SF8	13,6	15,8	18,8	>20	>20	>20	>20	>20	>20	>20
SF9	10,1	12,4	16,2	19,0	>20	>20	>20	>20	>20	>20
SF10	6,8	8,8	12,8	16,5	19,3	>20	>20	>20	>20	>20
SF11	4,2	5,8	9,3	13,2	16,8	19,5	>20	>20	>20	>20
SF12	2,5	3,5	6,1	9,7	13,6	17,2	18,8	19,7	>20	>20

A single event per frame.

For guidance and information purposes only.